

END SECTION

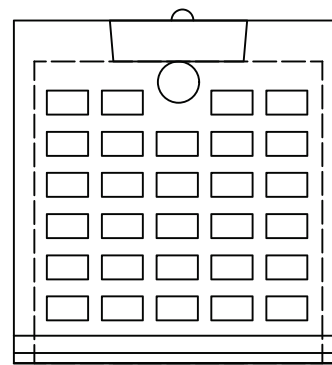
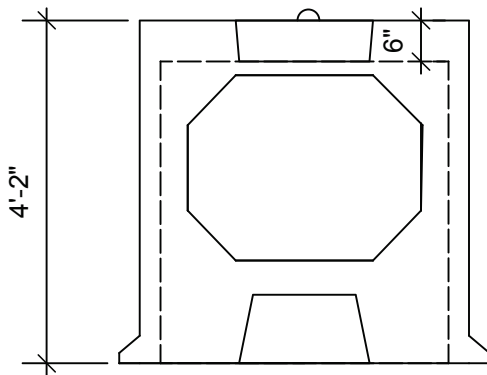

CENTER SECTION

4000 PSI CONCRETE @ 28 DAYS
 REINFORCING - ASTM A-615 GRADE 60
 AVAILABLE IN H-10 OR H20 LOADING
 WEIGHT = 2,300 LBS

MBO PRECAST, INC.

4 MARION DR. CARVER MA. 02330

PH: 508-866-6900 FAX: 508-866-5252



www.mboprecast.com



Show Name
4 X 4 GALLEYS

Reference

Drawn By

CMH

Date

5-30-12

CAD File Name